

WHEEL SKATE TROLLEY FOR BG

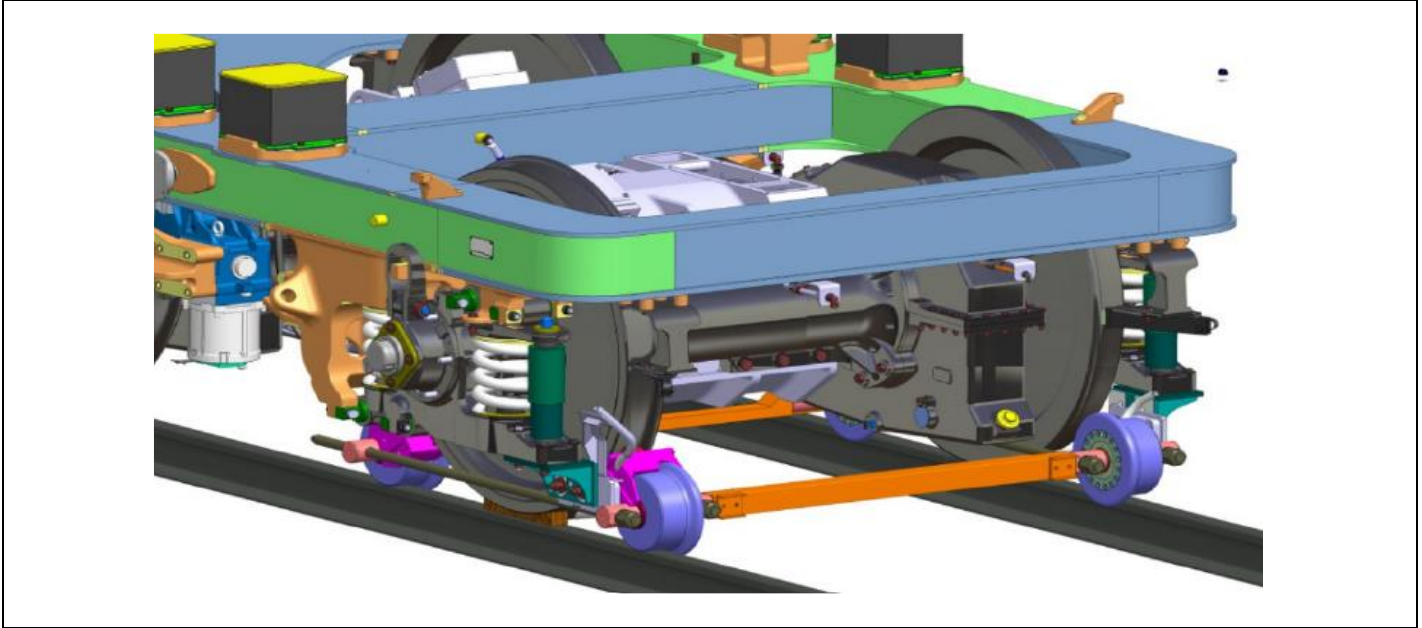

DESCRIPTION

LIGHT WEIGHT UNIVERSAL DESIGN, LIGHT WEIGHT TOWING TROLLEY SET (For locomotives & Rolling stocks)
Mechanical failures of any kind which blocks the track or makes the traffic stranded represent an enormous challenge for rail operators to get away with the situation at the very first moment. Removal of the rolling stock from the track must be safer, faster and without damaging the rail infrastructure or the rolling stock itself. .It should also require minimum number of operators.

BENEFITS

Feature of the wheel Skate.

History:It is generally observed that, to place the wheel skate underneath defective axle. the rail vehicle is lifted from one end to insert a duly pre-assembled trolley. Lifting of Rail vehicle from one end requires, lots of time & require hydraulic Re-railing equipment at the site of the incident. Bringing the equipment & setting up at site is time consuming however there was no option here before. Few rail cars do not allow lifting from one end.

Special feature of Bemco's Wheel skate

Bemco offers customised solution for the recovery of such rail vehicles which matches perfectly with the given rolling stock. Each wheel skate is planned and designed individually looking into design of the rolling stock and the Rail infrastructure.

The wheel skate, can be assembled directly underneath the defective axle just by lifting particular axle by 40 – 60 mm approximately against the suspension / spring of the rail car using any available jack of 20 Tons approx.

We mean to say that; re-railing equipment may not be required to set up for assembling the wheel skate / Trolley underneath the Rail vehicle if you purchase separate jacks and a small power unit from us.

TECHNICAL SPECIFICATIONS

Model	P04 - 1732
Maximum Axle Load	30 Tons
Rail Wheel Width	≤ 145 mm.
Wheel Tread Dia	780 – 1250 mm (Feature infinitely adjustable)
Main Features	Mounted directly around the defective wheel.
Lifting of Rail Vehicle	50 – 60 mm. (Approx.)
Scope of use	Any type of Main line rail vehicles
Track Gauge	1676 mm. / As per order
Towing Speed range	40 kmph on straight track 15 kmph on curves & cants
Total Weight	230 kg (Approx.)